

## Hydraulic Excavator Pump Attachment - 10 Inch

### MODEL #

10-Inch EXH 10000 Hydraulic Excavator Attachment

### OPERATING LEVELS

MIN FLOW	1200 GPM
MAX FLOW	5000 GPM
HEAD RANGE	Up to 200 ft
DISCHARGE SIZE	10 inch
SUCTION SIZE	12 inch
SOLIDS HANDLING	Solids up to 9 inches
MAX SPEED	1800 RPM
PERCENT SOLIDS	Up to 40-70% Solids
CU YD MATERIAL HR	300-350



\*Typical Attachment Photo. Photos for general guidance. Contact us for further details.

### RECOMMENDED SENSORS

Hydraulic Pressure Gauge for pumps and cutter head circuit to operator (0-6000 PSI)

Magnetic Flow meter to maintain stable plug free pipeline flow and maximize production

### REQUIRED EQUIPMENT TO OPERATE ATTACHMENT

EDDY Pump circuit requirements from excavator auxiliary power OR from Hydraulic Power Unit 120 GPM at 5000 PSI (500cc motor)

Cutterhead circuit requirements from excavator auxiliary power OR from Hydraulic Power Unit 20-28 GPM at 5000 PSI (2150cc motor)

10" material handling discharge hose and hydraulic lines plumbed out to the end of the boom

Crossover check valve to prevent damage to hydraulic motor and prevent pump rotor from coming off

Minimum excavator required 30-ton min, 300 Series (See OEM boom specs to verify.)

### MAXIMUM LINKAGE CROSS SECTION

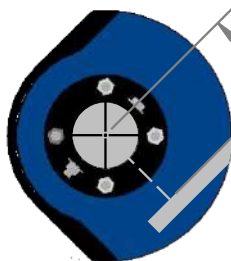

[140mm]  
5.5in

LINK PIN

STICK PIN

### STANDARD PIN SIZING

PART #	SIZE
12877	Ø 90 MM
06661	Ø 100 MM
01042	Ø 110 MM

\*CUSTOM SIZES AVAILABLE UPON REQUEST

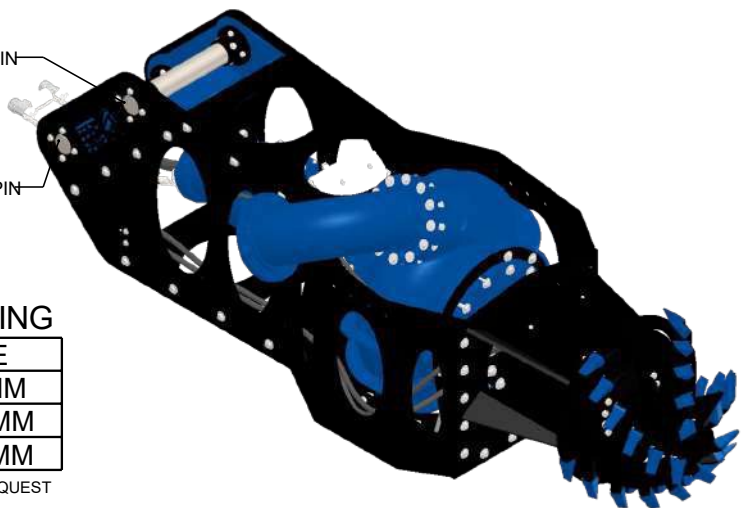



**EDDY Pump industrial Excavator Dredge Pump Attachments** are non-clog pumps designed for high solids industrial pumping applications. Our patented pump technology outperforms all centrifugal, vortex and positivedisplacement pumps in a variety of the most difficult pumping applications.

Available in alternative power options and pump sizes depending on your application.

### Applications

- Mining
- Chemical
- Sand & Agg
- Oil and Gas
- Paper & Pulp
- Fly Ash & Coal Ash

### Features and Benefits

- Non-Clog, High Viscosity, High Specific Gravity, High Abrasives, Low pH Pumping Design
- Transport 40-70% Solids
- Ability to pump objects of up to 9-inches in diameter

### Fluid Pumped

- Sludge
- Slurry
- Drilling Mud
- Mine Tailings
- Grit
- Sand Mixtures

## GENERAL SPECS

Overall Weight (without optional equipment)

7,500 lbs

3,400 kg

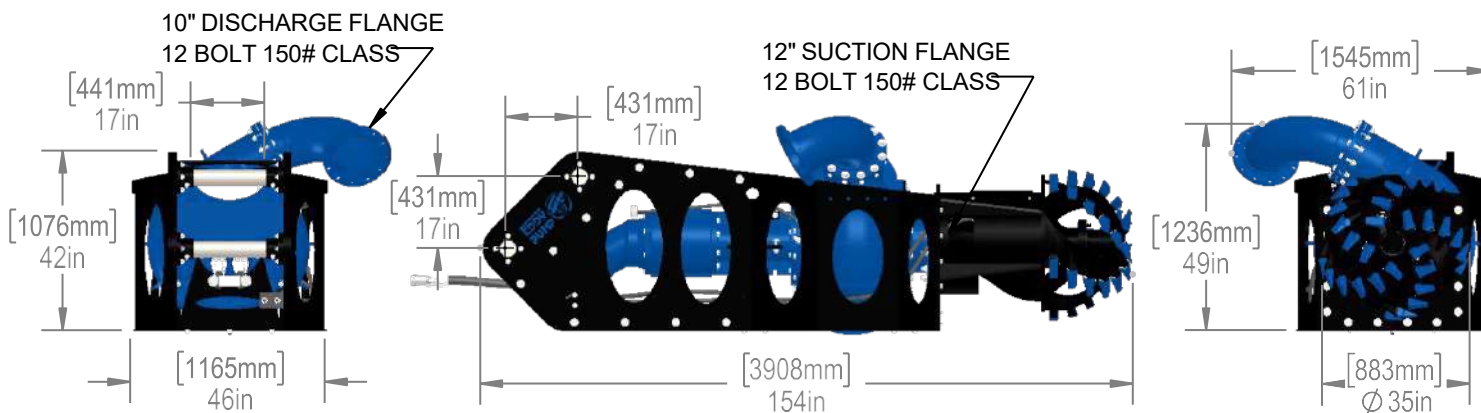





## OPTIONAL EQUIPMENT TO ENHANCE OPERATION OF DREDGE

Magnetic flow meter
Discharge line pressure gauge (0-150 psi)
"Quick Prime" Valve (requires small 24volt air system)
Pivot mounted Discharge hose carrier (adaptable to most machines)
Recirculation system for pre-mixing applications (requires small 24 volt air system)



STANDARD CUTTER HEAD



SELF-CLEANING HEAD



WATER JETTING RING



LINER-SAFE WHEELS



EXTENDED CUTTER HEAD



RE-CIRCULATION

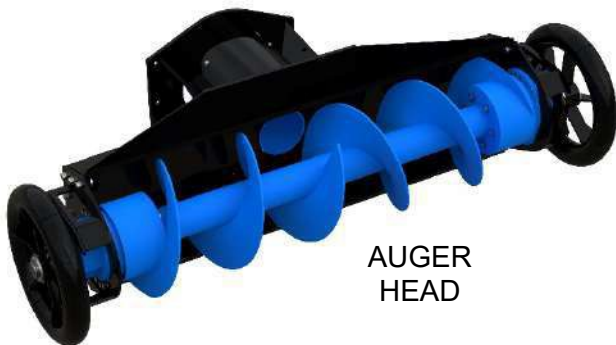

AUGER HEAD



MIXER HEADS

## PUMP CURVE

A pump curve is a graphical representation of a pumps ability to produce flow against a certain head. The science is matching a curve that is accurate for your project, leading to the proper pump selection and best efficiency. **EDDY Pumps** are primarily used for high solids, slurry, sludge, and dewatering.

### EDDY Pump - 10 Inch HD 10000 Heavy Duty Slurry Pump - Pump Curve

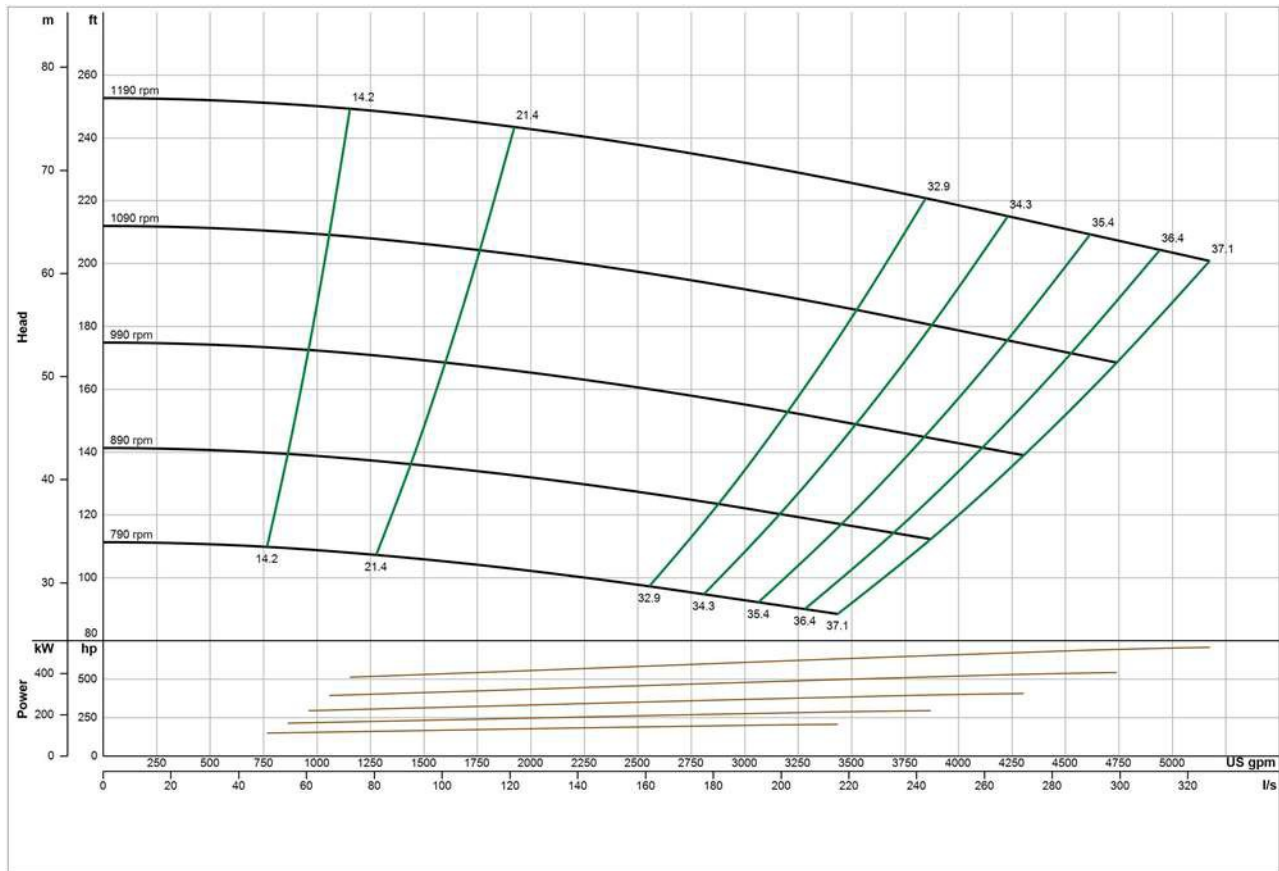

\*General pump curve based on water with 1200 RPM motor. Contact us with your specific material for a custom pump curve.

## WE PUMP SOLIDS, NOT WATER

CONTACT US



(619) 258-7020



info@EddyPump.com

## BASE PRICE ESTIMATE

### 10 Inch Hydraulic Excavator Pump Attachment - EXH 10000

**Description of Product:**

- 12 x 10-inch Hi-Chrome EDDY Pump
- 500cc Hydraulic Motor
- Frame, Cutterhead and Excavator mounting pins
- (Optional) Jetting Ring or Liner-safe Wheels

**Discharge Hose (Running length of boom):**

10-inch DAE Slurry Hose, Titan 777, or comp Goodyear Blucor. Connect to boom with weld on brackets, temporary brackets or clamps. Customer is responsible for acquiring and mounting.

**Hydraulic Power Needed to run off Excavator:** CAT 320 (or comparable) with Tool Control and Medium Pressure Circuit. Add a Case Drain. \*Beyond 100ft, Hydraulic Power Unit required.

**Discharge Pipeline:** Customer is responsible for acquiring and mounting 12 inch HDPE SDR-11 (10-inch ID) \*Depending on application.



\*Typical Deployment Photo. Photos for general guidance. Contact us for further details.

**EDDY Pump can provide full kit:** Discharge hose, Pipeline connectors or Hydraulic hoses at additional cost.

\*Additionally, case drain needs install: (1) 0.75" (-12) 1000 PSI rated hose for the case drain

### Prices - Shipping

<b>Excavator Attachment Unit Purchase Cost:</b>	\$173,250.00	
<b>Excavator Attachment Unit Monthly Rental Cost:</b>	\$19,425.00	
*(176 hours maximum per month)		
<b>Hydraulic Power Unit Purchase Cost:</b>	\$446,250.00	(Includes 150 ft Hydraulic Hose)
<b>Hydraulic Power Unit Monthly Rental Cost:</b>	\$26,250.00	
*HPU is required if material and pumping distance require more power.		
<b>Optional:</b> Jetting Ring (without water pump)	\$10,000	
Liner-Safe Wheels	Call For Price	
<b>Training/ Startup Cost:</b>	\$3,500.00	
Includes 1 day of on site training and start up. Additional days at \$3,000 per day.		

**Overtime Rate:** 100% of Standard Rate

**Shipping:** Responsibility of Customer. Calculated based on total weight and distance of shipment.

\*Baseline estimate is subject to modification based upon project demands and project scope changes. Final scope of work reviewed by EPC engineering and client, prior to entering contract.

**RENTAL TERMS & CONDITIONS:** EddyPump.com/Terms for current docs.

**Contact Sales for a Project Specific Quote:**

**Phone:** (619) 258-7020 **Email:** info@EddyPump.com

**EDDYPump.com**

EXH 10000 V4.2-Price Apr-2021